

CAD FILE:

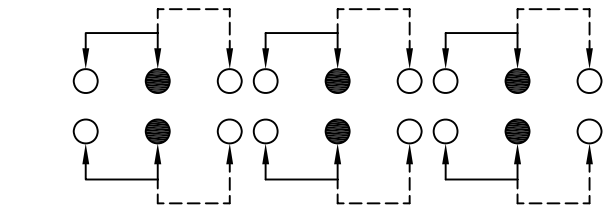

**SCHEMATIC (NON SHORTING)**

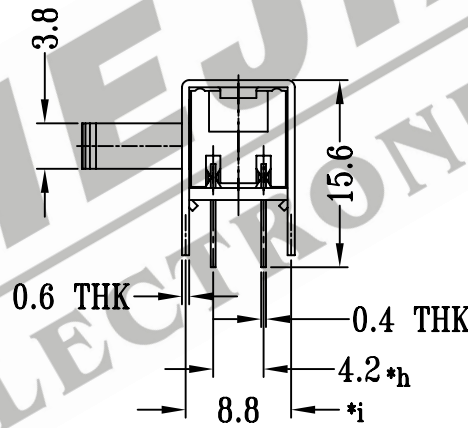
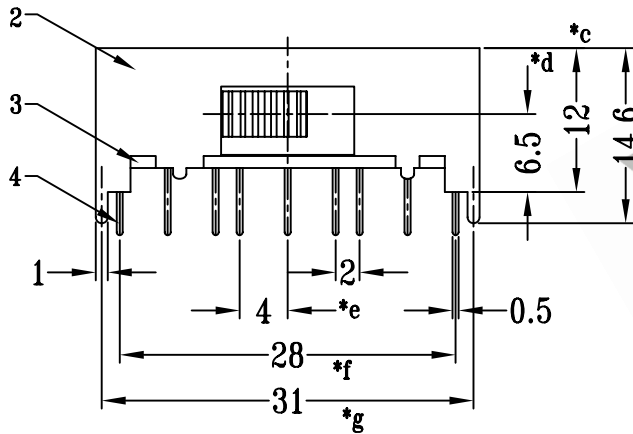
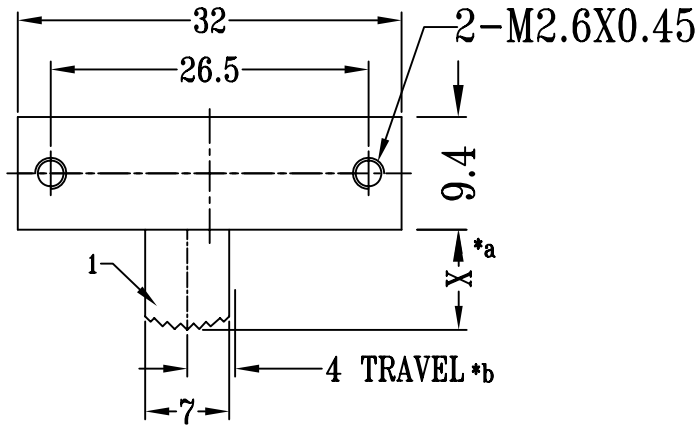
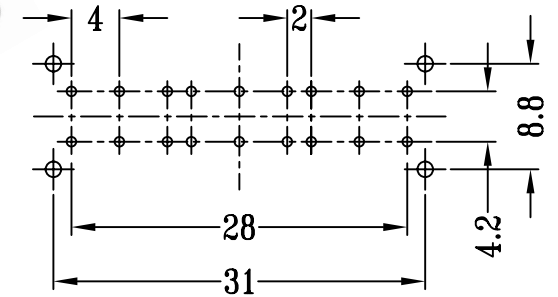

**P.C.B LAYOUT**

注:带"\*"表示关键尺寸(9个)

NO.	PARTS	MATERIALS	Q'TY	FINISH	TOLERANCE UNLESS SPECIFIED	SHENZHEN XIEJIA ELECTRONICS CO.,LTD.					
8						ISSUE	DATE	DESCRIPTIONS OF REVISION		APPD.	
7	STEEL BALL	STEEL	1	NATURAL							
6	SPRING	STEEL WIRE	1	TEMPER	WITHIN: 1.5±0.1mm OVER : 1.5±0.2mm						
5	CONTACT CLIP	PBS STRIP	6	Ag PLATED							
4	TERMINAL	BRASS STRIP	18	Ag PLATED OVER Ni PLATED		TITLE : HORIZONTAL SLIDE SWITCH		UNIT : mm	DRWG NO.: XJ-DR-SK62H11-00		
3	BASE	PHENOLIC RESIN	1	NATURAL		MODEL: SK-62H11		SCALE: 3:2	DWN.	ZHOUYU	2004-5-6
2	FRAME	STEEL STRIP	1	Ni PLATED					CHK'D	FANGYING	2004-5-6
1	KNOB	POM	1	BLACK		ALL MATERIALS MUST BE COMPLIANT TO ROHS		APPD.	KANGXINAN	2004-5-6	